

# Condensing Units

## DIRECT EXPANSION



J10 Condensing Unit Shown

### Features

- 5,000 - 16,000 Btu/hr.
- Reverse-cycle seawater-cooled condensing units
- Small footprint (13" x 13")
- Removable electrical box
- 115 and 230V, 60 Hz; 220/240V 50 Hz models
- Ignition protected
- Dependable reciprocating compressor
- Properly-sized accumulator and receiver
- Rubber isolation mounts
- Wiring hookup on color-coded terminal strip
- High Pressure Switch
- JX Series for use with SMX II Controls

### Type J Models

Type J condensing units are designed for applications where space is limited. These units have a slightly smaller footprint (13 x 13 inches) than Type F units and a detachable electrical box, which can be remotely mounted up to 3 feet away. Type J units are used with Cruisair manual switches. They can be used with SMX-series controls on special order.

All Type J units are reverse-cycle heat pumps for cooling and heating. When running in the reverse-cycle mode, the Type J unit provides heat in seawater temperatures down to 40°F (4°C). Cruisair auxiliary duct heat modules can be used to provide supplementary heat in very cold water.

The Type J assembly includes a dependable reciprocating-type refrigerant compressor, a cupronickel refrigerant condenser, reversing valve, refrigerant receiver and accumulator, and other electrical and mechanical components on a single chassis with rubber vibration-isolating mounts.

The Type J condensing unit is designed for installation in the boat's engine room or other mechanical space, along with the seawater pump and associated plumbing. Multiple condensing units can be rack mounted to save space. Copper tubing is used to carry refrigerant between the condensing unit and the cooling/heating units, which are located in the boat's living spaces.

The unit is not affected by moisture, vibration or ambient temperatures up to 140°F (60°C). No ventilation is needed and all components are ignition protected.

Type J units are pre-charged at the factory with R-22 refrigerant gas, which is released into the refrigerant tubes and cooling/heating unit when the system is installed. Installation and final charging of the system must be performed by a certified technician using EPA approved equipment.

Type J models are available in capacities of 5,000 - 16,000 Btu/hr, for 115 or 230V, 60 Hz and 220/240V, 50 Hz AC power. For larger capacities, Type F units must be specified.

**Cruisair**<sup>®</sup>  
Chill Out In Style

### SPECIFYING GUIDE

Capacity Btu/hr	Refrigerant Connections		Pump Capacity gph/lph
	Discharge	Suction	
5,000	1/4	3/8	100/400
7,000	1/4	3/8	150/570
10,000	1/4	3/8	210/810
12,000	1/4	3/8	250/970
16,000	1/4	1/2	330/1,300

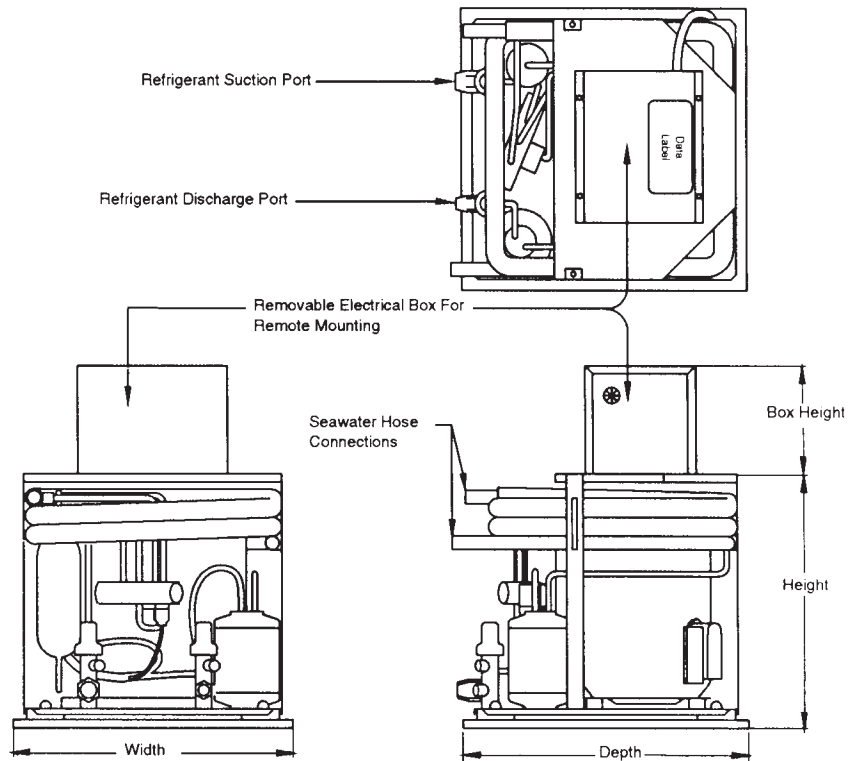
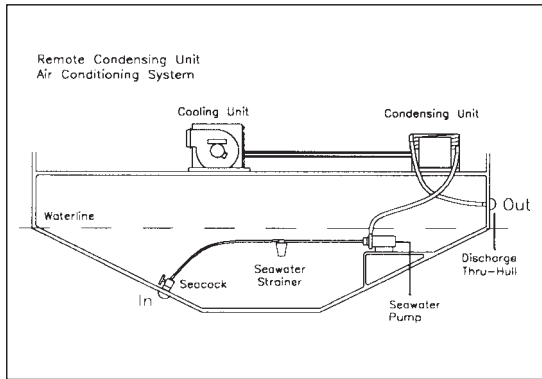

### TECHNICAL SPECIFICATIONS

Model	Capacity (Btu/hr)	Voltage VAC	Full Load Amp	Freq. (Hz)	Height (in/mm)	Width (in/mm)	Depth (in/mm)	Box Height (in/mm)	Weight (lb/kg)
J5	5,000	115	7.2	60*	12.75/324	13.0/331	13.0/331	5.5/140	51/23.1
J7, JX7 J7C, JX7C J7CK, JX7CK	7,000	115 230 220/240	8.7 4.5 3.3	60* 60* 50	12.75/324	13.0/331	13.0/331	5.5/140	52/23.7
J10, JX10 J10C, JX10C J10CK, JX10CK	10,000	115 230 220/240	11.4 6.0 5.3	60* 60* 50	12.75/324	13.0/331	13.0/331	5.5/140	60/27.2
J12, JX12 J12C, JX12C J12CK, JX12CK	12,000	115 230 220/240	12.0 6.4 6.2	60* 60* 50	12.75/324	13.0/331	13.0/331	5.5/140	62/28.1
J16, JX16 J16C, JX16C J16CK, JX16CK	16,000	115 230	14.0 6.7	60* 60*	12.75/324	13.0/331	13.0/331	5.5/140	64/29.0

\*115V, 230V, and 440V 60 Hz equipment can be operated at 100V, 200V, or 380V respectively, in a 50 Hz environment. In such a 50 Hz environment, performance will decrease by 17%. Full rated capacity can be obtained by specifying Cruisair "CK" equipment.

**NOTE:** Compressor starting current will vary with voltage and is approximately 3-4 times the full-load amps.

### INTERPRETING MODEL NUMBERS

